



001

We Are 001.

In the spring of 2017, a group of industrial design and architecture students united to create a new kind of collaboration— a studio that would later come to be known as *Section 001*. Their original stated mission was to design a furniture collection for millennials, by millennials.

After months of extensive research, investigation, and construction, they created a collection titled *Midwest Modern*- named after the region in which the students live and study. In addition, they also formed an identity— *Section 001*, adapted from the administrative code of their class. The student team then took their work to the International Contemporary Furniture Fair (ICFF) in New York, where the standard and quality of the collection was so high that they received the *Mind the Grid: Creative Workspaces for the [Near] Future, The Work “Editors’ Choice”* award.

The major success of this studio inspired future students to continue the work they began— inspiring, inventing, and designing under the same name. From then on, each year takes on new challenges and topics, culminating in the work’s exhibition at ICFF. This year, after a few year’s break due to the pandemic, ***Section 001 is back and has shifted its focus once more, partnering with Cincinnati Center City Development Corporation (3CDC) to design site-specific urban furniture installations at a local public green space in the Over-the-Rhine (OTR) neighborhood- Washington Park.***

While the students who partake in this course are no longer millennials, the legacy of *Section 001* continues to be built today.

Contents

02	We are 001
06	Project Description
08	History of Public Space History of Public Space Users and Controllers of Public Space Recreation and Action in Public Space
28	3CDC & Projects Fountain Square Ziegler Imagination Ally
38	Washington Park History Users and Controllers Recreation and Action
52	In Public Space Object Analysis/ Opportunities
66	Process Ideation
70	Proposals Fabrication and Prototyping Proposals
158	The Class

Project Description

“Public Space,” is a two-word phrase in tension with itself because of each word’s capacity to undermine the other.

This year’s Section 001 is partnering with 3CDC in the design and production of a series of site-specific urban furniture installations for parks they manage in OTR. This spring the studio will conceive and produce installations that slip in between the conceit inherent in the notion of “public” and “space”, by redefining the arena, actors, artifacts, and actions, that comprise it.

As a subcategory within industrial design, furniture is uniquely positioned to accomplish a wide variety of tasks not typically tackled by the field in its more general applications. Furniture can alter the behavior of a singular person or large groups of people. It can communicate how it is or is not to be used, how it is made, as well as who made it. It can refer to the history and the future of craft, can comment on materiality, can comment on and establish place, and can (and often should) serve as more than simply a tool to afford its users the perception of comfort. Furniture can be defined *by* its context, but it also has the power to define its context. Through this semester, we will conduct research in order to better inform a variety of potential design directions- ultimately, to be shared with 3CDC at a progress critique roughly a third of the way through the semester.

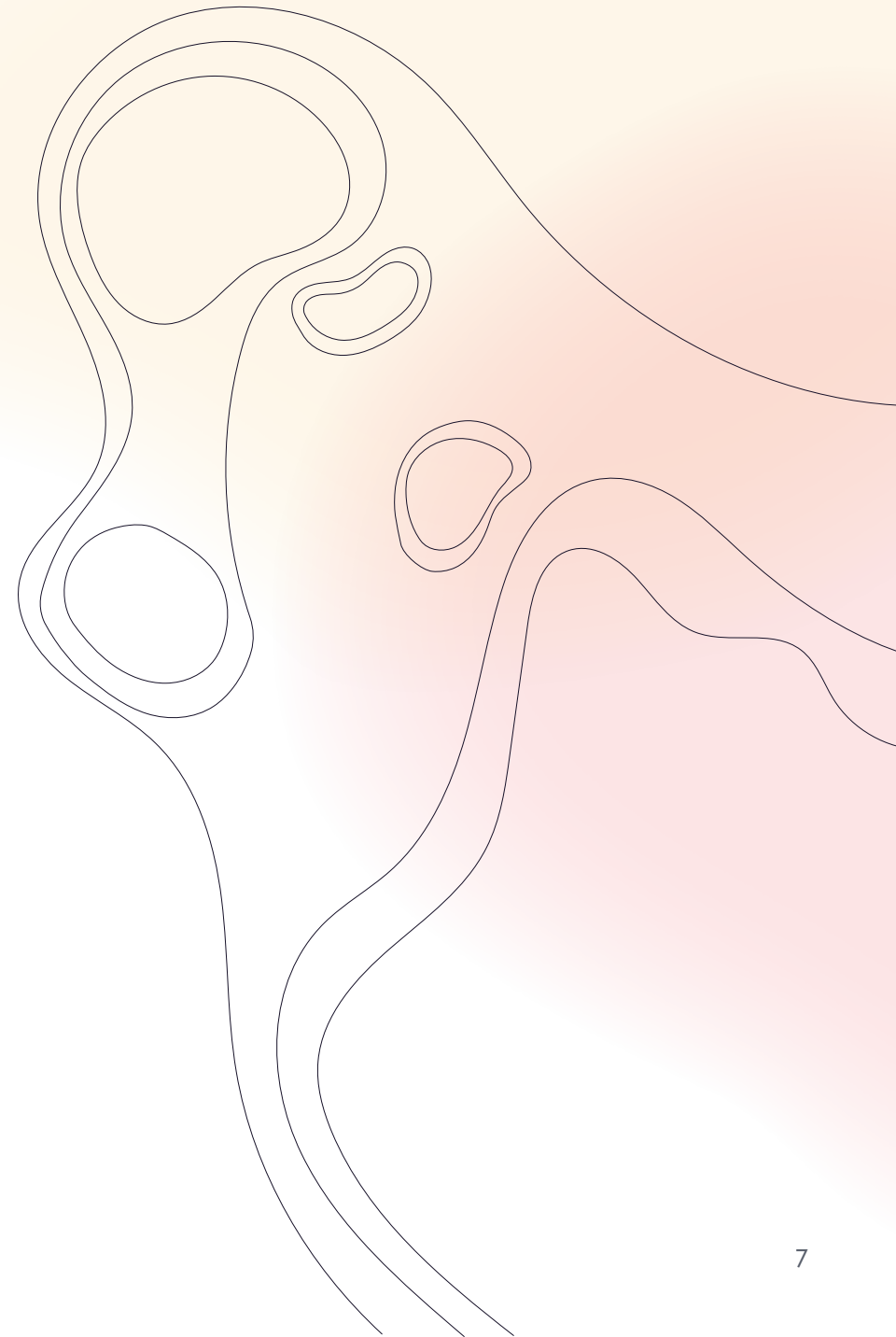

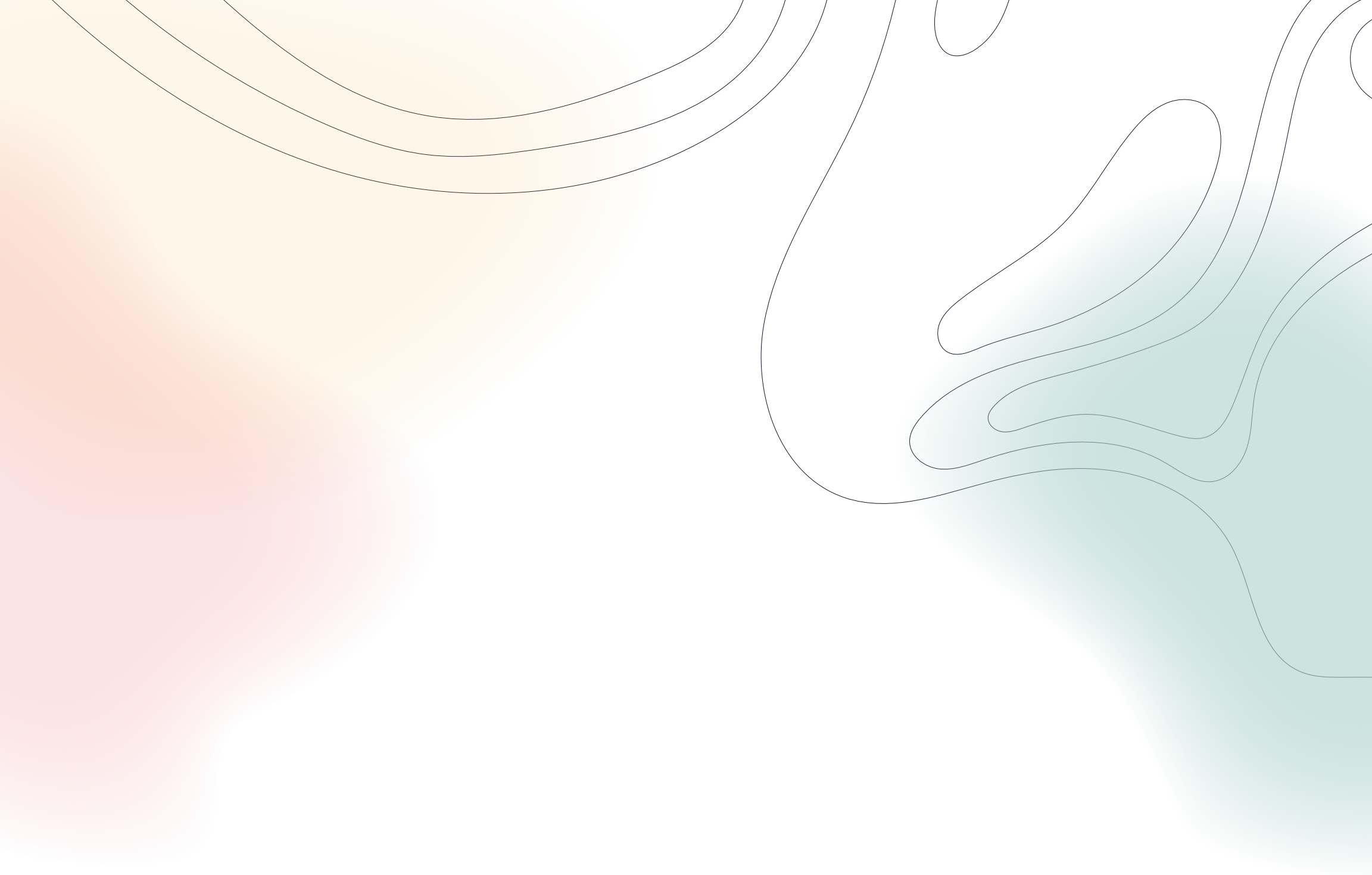

History
Chapter 01

History of Space

Public spaces have been around for thousands of years and utilized for everything from celebrations to grievances, from recreation to prayer, and everything in between. From the first Roman forum to the emergence of cyberspace today, public space has been integral to fostering connections among friends, family, and even strangers.

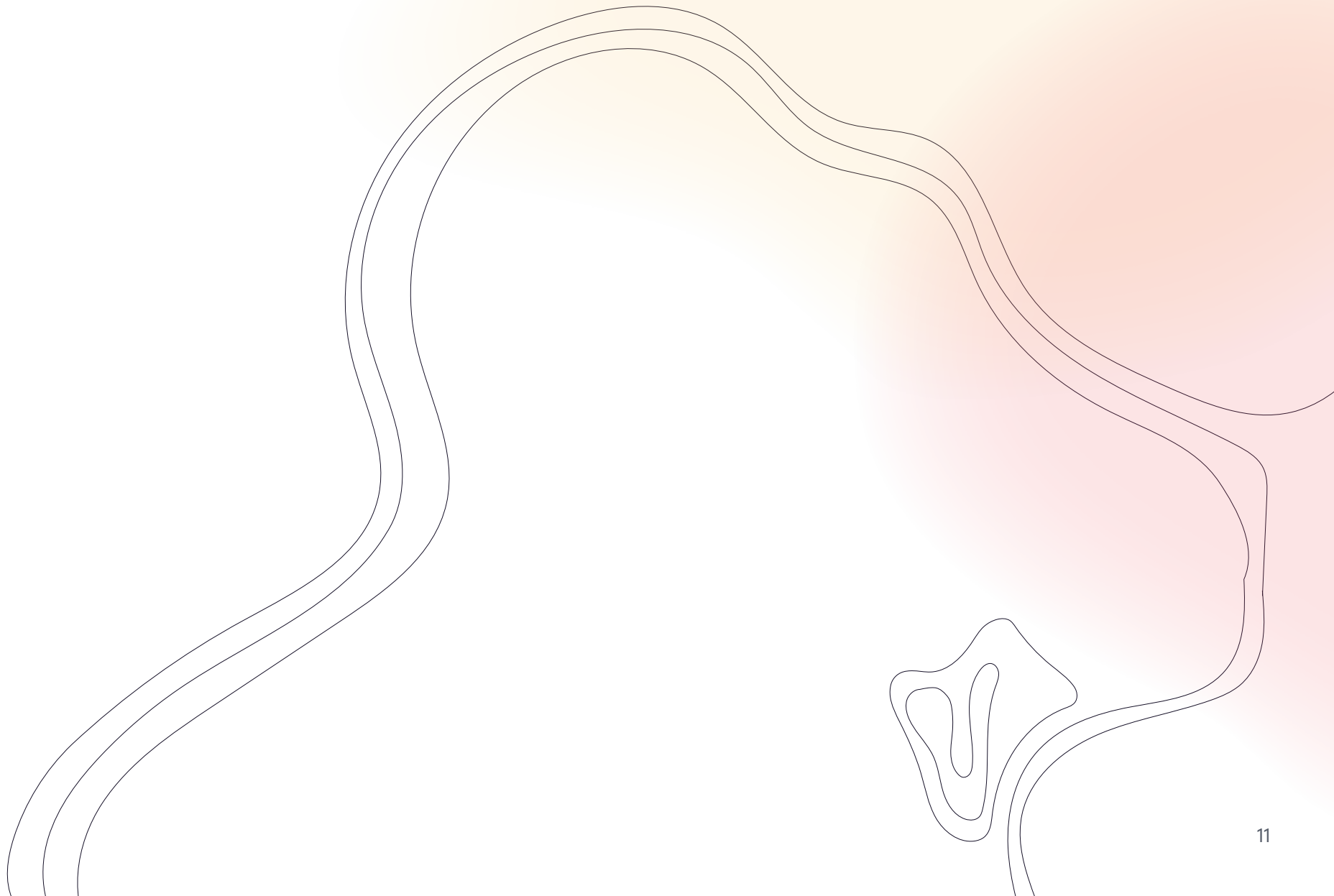

History of Space

First Public Space

The first recorded account of public space was around 500 B.C. during the Roman Empire, where Romans would gather in forums to discuss politics and lead prayers. Around the same time, the Greek Empire also had its own public space; the agora. However, the agora was used for more recreation-based activities, where the citizens would peddle their wares, lead communal activities, and relax. These two different public spaces would lead to the foundation of parks, malls, and government buildings, as well as all sorts of public spaces that became a fusion of politics, recreation, and more.



Industrialization

As time went on, public spaces arose in prominent locations throughout cities, usually temples, main roads, and churches. They were mostly centers for commerce and relaxation. Most green spaces were privately owned, and citizens had to pay to enjoy the greenery, so gardens, hunting grounds, and other green spaces quickly became symbols of status and power.

The industrial revolution caused a mass of people to move from rural to urban areas where there was usually no nature or quiet places in the city. People that moved to the city were working in factories and were very poor, but with the introduction of the 40-hour workweek and more ethical labor laws, a need was created for more public spaces geared towards relaxation.

Birkenhead Park opened in 1847, making it the first truly public park, where no one had to pay for access, and everyone had the opportunity to relax and recreate. This park in England inspired countless parks around the world- most notably Central Park in New York City. Originally, there were concerns about the cleanliness of the park, as people were worried about vandalism and crime. However, the citizens seemed to value and respect the common ground, so that worry was easily dispelled.

History of Space

Contemporary Public Space

Throughout the 20th century, more and more governments started converting private property into public property. Not all governments fairly compensated the property owners for the land that was taken, so all of the hunting grounds and gardens that were originally privately owned were seized and became the basis for many public parks. In America, public spaces exploded in popularity. From malls to waterparks to farmers' markets, public space became synonymous with commerce. Even though these public spaces are accessible for free, oftentimes there exists an expectation to purchase something from a private vendor.

Cyberspace

Over the last 20 years, the explosion of social media and internet forums have created a new form of public space; cyberspace. Cyberspace has enabled strangers from around the globe to talk about shared interests, compete in games and skills, and plan events to occur in reality, such as flash mobs, concerts, and other events. Citizens are now more aware than ever of their surroundings and have more information about global events, as well as local events within their communities. Cyberspace has opened the doors to a new way of interacting in public space- and with the development of AI and virtual reality (VR), the next few years will dictate the future of public space as we know it.



Users and Controllers of Public Space

Who, both historically and in contemporary times, uses and controls public spaces? A public space is nothing without the community that it fosters, the users it attracts, and the users it estranges.

Users and Controllers of Public Space

Historic Users of Public Space

In the past, segregation has ruined public space, alienating certain users, typically minorities and the poor, from accessing their right to public space. Today, the exclusion of users is not completely diminished. The objects installed within public spaces recently, have served to prevent the homeless and other users deemed by the controllers of public spaces as “undesirable”. For example, defensive architecture has ostracized the homeless from utilizing public spaces for rest in urban environments.

Contemporary Users of Public Space

Public spaces have however, also become more inclusive for others- such as an overall effort to make public spaces more accessible to those with mobility impairments. The abstraction of public installations has also included more users than ever to be able to interact, contribute, and appreciate public space, blurring the line between public art and intended functionality.

In an ideal society, everyone not only has access to public spaces but access to proper public spaces within their communities. In the past and present, objects and their relation to public space have included and excluded certain users. Public space is nothing without the community that it fosters, the users it attracts, and the users it estranges.



Case Studies

Monuments aim to celebrate important societal figures or achievements; they can bring inspiration and appreciation to the users of public spaces. However, they can also bring about mixed emotions or anger when the topic of celebration is not something that everyone agrees with. These types of monuments can make public spaces unwelcoming and create a hostile environment. Newer monuments can provide opportunities to celebrate those who haven't been historically celebrated and thus create a sense of community for those who have been historically discriminated against.

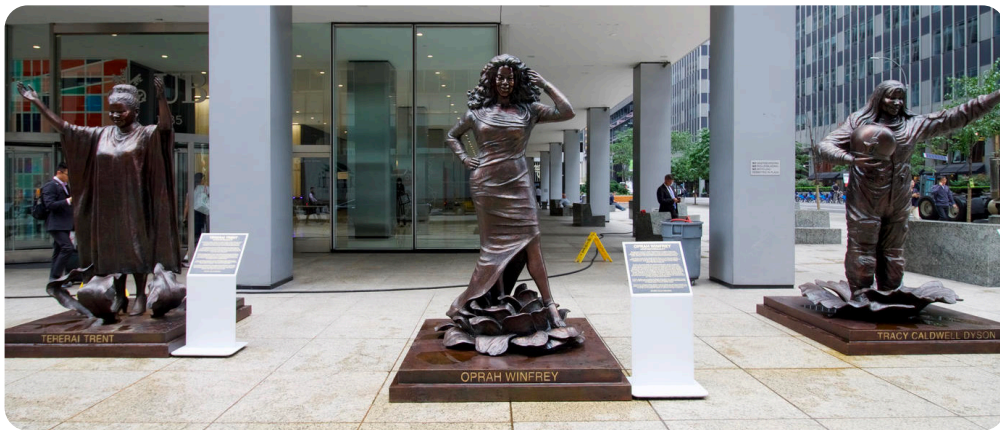

There are subtle communicators within public spaces that aim to exclude users. The most common example in urban environments is defensive architecture. This serves to prevent the homeless from using public spaces.

Abstraction has been a recent focus in public space. When abstract objects are implemented into public spaces, they invite unexpected users and create a welcoming aura to the area. Abstraction blurs the lines between public art and spaces with intended functions.



Inclusivity is a necessary part of public space, and more recently, users who need these accommodations have been accommodated. Incorporating accessible objects and furniture is a step in making public spaces inviting for everyone.

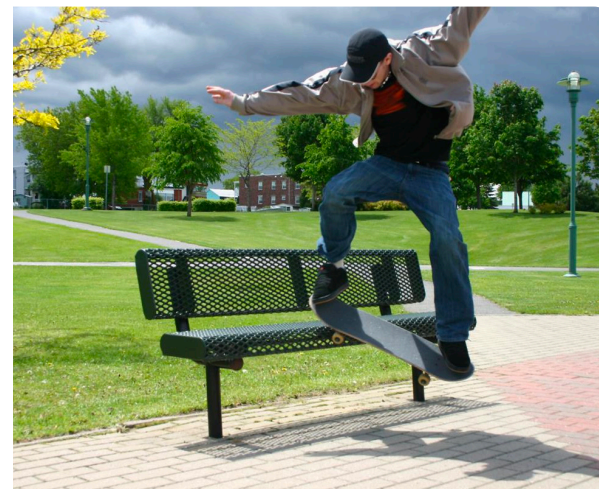

In public spaces, objects are not always used for their intended purposes. For example, skateboarders tend to use benches, railings, etc. for tricks and their artistry.

Users and Controllers of Public Space

Controllers of Public Space

Public spaces are “market failures”; a good or service that will never be supplied for a profit but still benefits society. Universally, in ancient civilizations, their governments were the creators and controllers of public spaces. Until 1847 there existed no documented evidence of public spaces dedicated solely to the common peoples’ enjoyment. Emperors, kings, and other rulers owned private lands and gardens, but often the individuals who funded the spaces were unable to use them. The first publicly funded park was Birkenhead Park in Liverpool, England. Birkenhead was a response to the urban blight of the industrial revolution.

The regulation as to what types of activities were permissible in these early public spaces was often scarce and unpredictable. Many of the strangest laws in U.S. history dictate actions forbidden in the public realm.

Controllers of Washington Park

In the United States, and specifically in Ohio, public parks are funded by a levee of tax dollars, which the *board of park commissioners* allocates to the funding of landscaping, building facilities, and general upkeep. This governing body also decides the activities that are permissible within the park.

There is another structure for public spaces where private companies receive control of public land. The city gives these companies real estate zoning exemptions in exchange for the upkeep of the public space. This is the structure used in Washington Park. Zoning of the land requires this land to be public, but the company in charge of the land controls the space and regulates what kinds of activities are permissible within the space. In the case of Washington Park, decisions pertaining to the space must ultimately pass through the *department of parks and recreation of downtown Cincinnati*; other entities can be responsible for the beautification and renovation of the space. 3CDC is a private company that maintains Washington Park and other parks throughout the city.



Users and Controllers of Public Space

Recreation and Action in Public Space

Public spaces are gathering places for people to have their voices heard and enjoy the community around them. They are a form of democracy where people are free to exchange information and opinions. Public spaces are versatile places where relaxation and public action all happen. **Activities that take place in public spaces have changed over the years but still hold a fundamental part in culture and community.**



69% of people will live in urban settings

Why We Use Public Space

People use public spaces to experience a break from their every day, cramped urban surroundings, improve their mental and physical health, and engage with their community.

Public areas are becoming increasingly important, especially as the world's population continues to move towards city centers. The United Nations predicts that by 2050, 69% of people will live in urban settings, meaning spaces like parks will become all the more necessary. The increasing scarcity of open, green spaces will most likely result in the increased popularity of these areas.

In fact, as the COVID-19 pandemic first swept the United States, park attendance increased by 63.4% prior to their shutdown. Tired of enduring the same environment of their own homes where they worked, slept, ate, and more, people found solace in the break that parks provided from the monotony.

Public protest is the manifestation of the peoples' voice within the public good- throughout history, bringing attention to a cause, i.e. the gathering of people to demonstrate, listen to speeches, or obstruct a condition of the norm within the status quo.

63% increase in park attendance during COVID

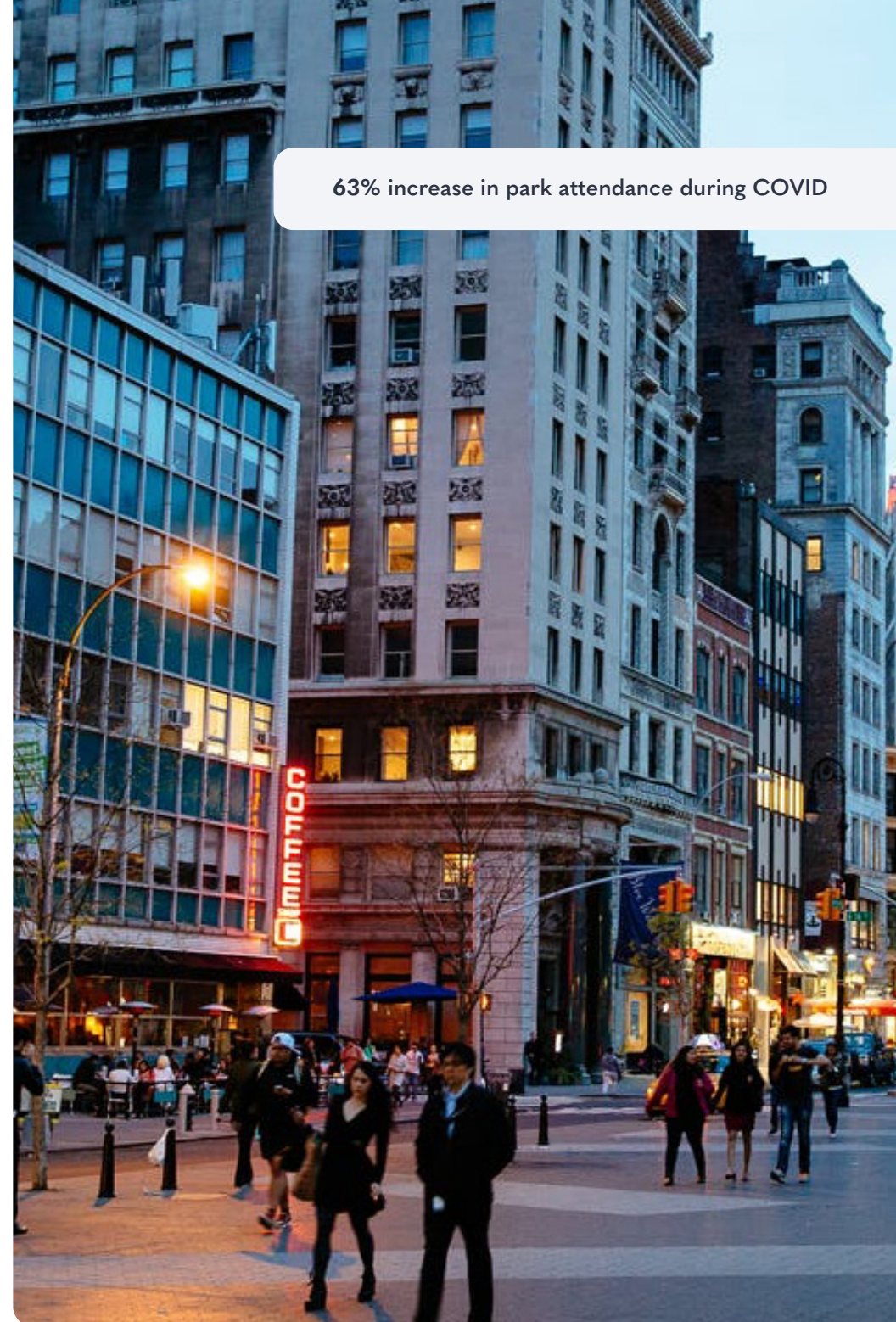

Case Studies

Cincinnati Riots of 2001

In response to the killing of Timothy Thomas and many other black people killed in the years prior by police, the *Cincinnati Riots of 2001* shone a spotlight on the racial divide in the OTR neighborhood, as well as the divide in the city of Cincinnati as a whole. Actions to put more aid into OTR and create a safer city were enacted after the conclusion of the riots.

These riots took place in parks and throughout the streets of the OTR community, and yet there was no mention of Washington Park, located in the very center of OTR. There is only mention of protests at Fountain Square Park and surrounding OTR streets.

2001: Riots and protests started at Fountain Square Park and moved to the OTR neighborhood.

2021: 20-year remembrance march started at Washington Park and surrounding OTR streets.

In just 20 years, the image of Washington Park was transformed into a place where people wanted to gather and voice for change.





3CDC and Projects
Chapter 02

Who Is 3CDC

The Cincinnati Center City Development Corp. (3CDC) is a 501(c)(3), tax-exempt, private, non-profit corporation. Its mission and strategy focus on strengthening the core assets of downtown by revitalizing and connecting the Central Business District and Over-the-Rhine (OTR). 3CDC was formed in July 2003- recommended by a City of Cincinnati Economic Development Task Force as part of an overall system to increase the effectiveness and efficiency of development activities in the City of Cincinnati. Then-Mayor Charlie Luken and members of the Cincinnati corporate community joined together to create 3CDC, agreeing that the economic future of Cincinnati depended first and foremost on strong and vibrant downtown business and entertainment district. Its operations are funded privately, through a combination of corporate contributions, management fees, and below-market developer fees. In November 2004, the staff of 3CDC accepted the daily operating responsibilities for two private investment funds, the Cincinnati New Markets Fund (CNMF) and the Cincinnati Equity Fund (CEF). These loan funds are geared toward downtown redevelopment and spurring economic development in distressed and struggling neighborhoods. 3CDC works collaboratively with the City of Cincinnati and the State of Ohio. Also among 3CDC's partners are members of the Cincinnati corporate community. Cincinnati is fortunate to have a very strong and engaged base of corporate leadership. Nearly 30 corporate leaders make up 3CDC's Board of Directors and are vital to 3CDC's existence and success.

More can be found at www.3cdc.org



Fountain Square

Mission:

To serve as the epicenter of downtown and the city's main gathering space; the hub of Cincinnati's civic, social, and commercial life.

History:

Once a butcher's market, the space was transformed into a plaza with the gift of the fountain from Henry Probasco, a local businessman, to "The People of Cincinnati", in memory of his business partner Tyler Davidson in 1871. It has served as the heart of downtown ever since, despite experiencing several slight relocations throughout the years. Now, one can see markets, demonstrations, festivals, parades, and more in this square. In the winter it is transformed into an ice rink.

Features:

- Public Seating
- Fountain
- Bar and Concessions
- Wifi
- Events: ice rink, booths, food tents, City Flea, etc

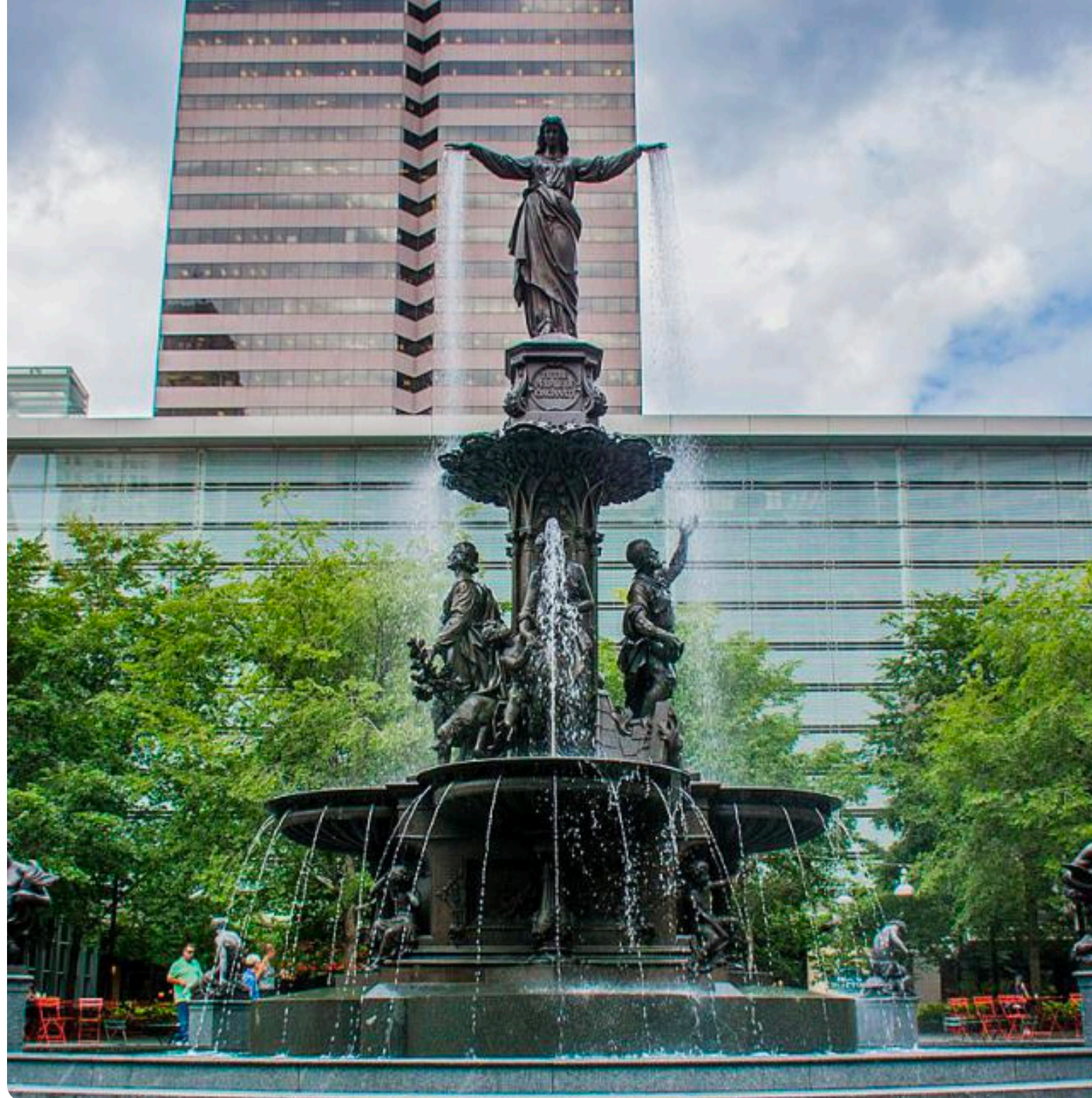



Ziegler Park

Mission:

To build community and engage the area's youth with inclusive recreation and leisure.

History:

Ziegler Park is named after Cincinnati's first mayor, David Ziegler. It currently boasts a city-owned green space between the neighborhoods of OTR and Pendleton, serving local communities as a recreation-centric park. However, the area today looks very different than the park about ten years ago. It wasn't well taken care of, and it was a hub of crime and drug activity. When local philanthropist Milton Kantor passed away in 2012, his family wanted to do something to help out the community as a way to honor him. They approached 3CDC with an idea to renovate Ziegler Park, and after a few years and lots of community input, the park reopened in 2017.

Features:

- Wifi
- Playground
- Lawn
- Pool
- Basketball
- Games (Ping pong, bocce ball, chess/checkers)

Imagination Alley

Mission:

Everyone is welcome here. Black lives matter here. People matter here. For some, this is our yard in the city. It's a gathering place for quiet, for conversation, for family fun. We want everything to be respected, safe, and culturally embraced. The peoples' art and creativity can flourish here. We are family, all part of the Beloved Community

History:

Imagination Alley is a small park located on the 1300 block of Vine Street. Recently, it was renovated by 3CDC, as the space had been underutilized in past years. Now, it serves as a community and welcoming space for all.

Features:

- Wifi
- Eating area
- Local wooden seating
- Movie Projector
- Murals



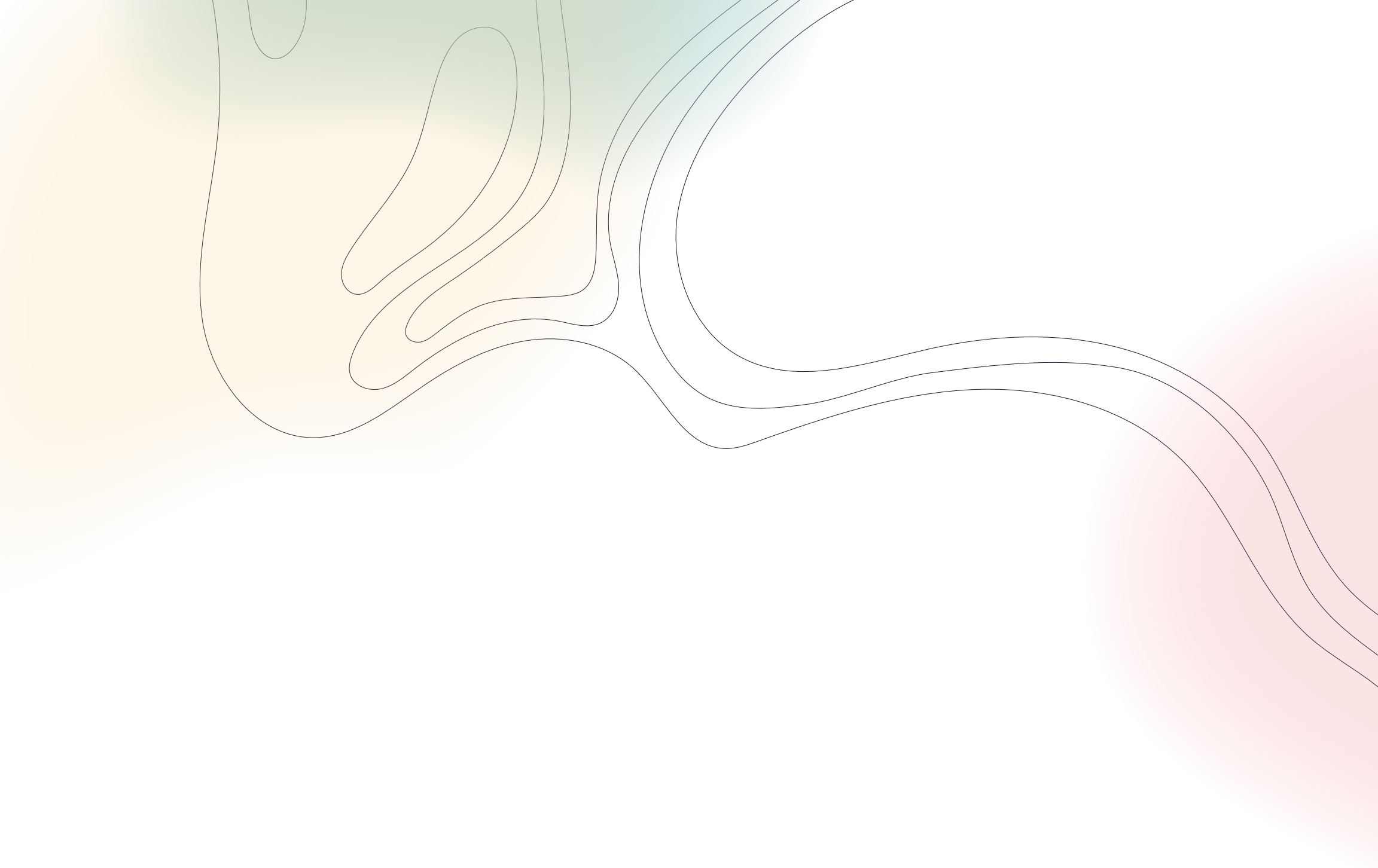

Washington Park
Chapter 03

Washington Park

Mission:

To serve as the epicenter of OTR's multi-generational and multicultural district and to reflect the changing neighborhood.

History:

The park was established in the 1860's, serving the OTR population at the time, mostly German immigrants. The area thrived on sales of brewing from the wealthy German Beer Barons in the area, and so after WWI and Prohibition, many of original residents had fled or left. The park experienced decline in the following years, but in 2008, 3CDC and the city organized a plan to renovate. The park was reopened in 2012, and is now one of the most popular gathering spaces in Cincinnati. See the following pages for a more detailed history of Washington Park.

Features:

- Porch
- Playground
- Interactive Water Fountain
- Dog Park
- Bandstand
- Stage
- Open Lawn
- Parking



In-Depth History of Washington Park

To the average person who lived in OTR before 2008, the current condition of Washington Park would be nearly unfathomable. The area's transformation throughout history is a tumultuous story- rich in culture, conflict, and art. On the following pages is a brief glimpse of what Washington Park once was, and what it is today.



The Rise



Fort Washington
1789-1808

Initially built by settlers as a fortification during White and Indigenous hostility, the garrison soon moved to Newport in 1804 to make room for a growing city. This is the namesake of the park.



Episcopal Cemetery
1800-1855

Once settlers took over the land, Presbyterian and Episcopal churches use the land for cemeteries.

1888



Washington Park Created
1860

After the city acquired the land in 1855, they constructed a park for residents of downtown.

Music Hall
1878

Originally, Music Hall was used as a convention center- hosting sporting events, art shows, and even political national conventions.

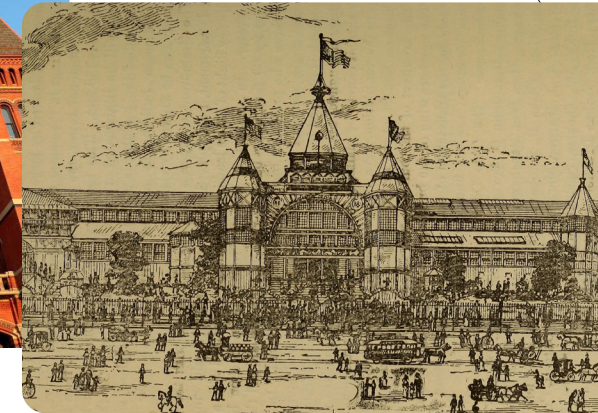

Centennial Exposition
1888

The Centennial Exposition of the Ohio Valley and Central States was held at the park to celebrate the settlement of the Northwest Territory. Huge temporary structures were installed for the event to showcase the best of the Industrial Revolution.

Decline

1914

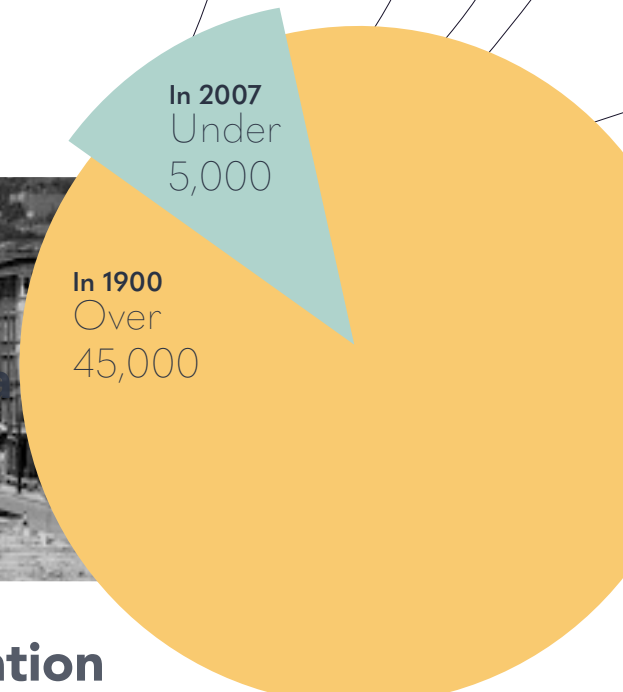

Plan for Renovation

Area Population

World War I 1914-1918

Germans started leaving OTR in mass due to anti-German hysteria from WWI.

Prohibition 1919

The 18th Amendment and its following laws prohibited the sale of alcohol. Now most of the people who once worked in OTR no longer had a business.

Drop Inn Shelter 1973

An anti-gentrification activist named Buddy Gray officially opened the Drop Inn Shelter and soon created a 200+ capacity homeless shelter in OTR.

Cincinnati Civil Unrest 2001

In the aftermath of an Timothy Thomas, an unarmed African American, being shot and killed in OTR, protesters moved from Fountain Square towards Over the Rhine, where he had lived. A riot broke out soon after, and the increased violence frightened people and thus deterred them from moving into the neighborhood.

Washington Park Elementary Demolition 2007

The Washington Park Elementary school was removed from the area in 2007. By this point, the population in OTR had fallen under 5,000 residents, a mere fraction of what it once was in the 1900s.

New Beginnings



2012

3CDC and Cincinnati Parks 2008

Cincinnati Parks was given the land from the school board after the destruction of the elementary school. They then collaborated with 3CDC and began their plan to revamp the struggling area.

School for Creative and Performing Arts 2010

Cincinnati's School for Creative and Performing Arts was moved to be across from the park.

Grand Reopening 2012

When the park re-opened, nearly 30,000 attended its grand reveal. Improvements to the park included a fountain, a dog park, a revamped band stand, and a large courtyard for miscellaneous activities.



Now

Users of Washington Park

Thousands of community members and tourists make use of the park everyday. Whether it be children playing in the fountain, or patrons looking for a nice drink at the Porch, people of all ages, races, and incomes use the park as a communal gathering place.

Recreation of Washington Park

Currently Washington Park has activities every day of the week, from yoga classes to holiday markets, to encourage the community to come out and interact with each other. There is a wide range of activities available for every age group to ensure that everyone will be able to enjoy their time.

Washington Park provides the surrounding area and beyond a space to gather in community, enjoy a variety of activities, and relax in a green space in the midst of downtown Cincinnati.



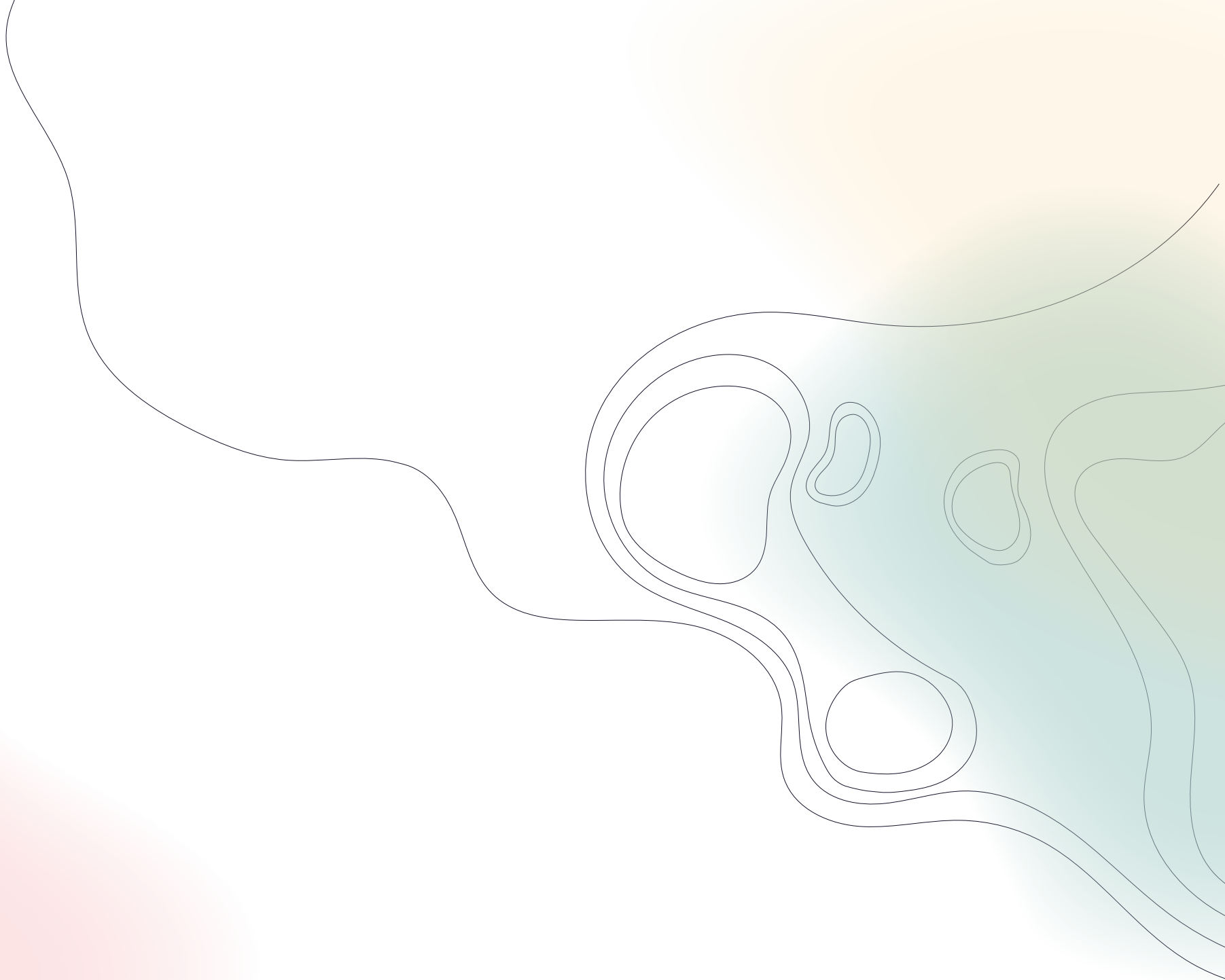

In Public Space
Chapter 04

Terms

Education

- The process of receiving or giving systematic instruction, especially at a school or university.
- Information about or training in a particular field or subject.
- An enlightening experience.

Community

- A group of people living in the same place or having a particular characteristic in common.
- A group of people living together in one place, especially one practicing common ownership.
- A feeling of fellowship with others, as a result of sharing common attitudes, interests, and goals.

Relaxation

- The state of being free from tension and anxiety.
- Recreation or rest, especially after a period of work.

Necessity

- The fact of being required or indispensable.
- A state of things or circumstances enforcing a certain course.

Beauty

- A combination of qualities, such as shape, color, or form, that pleases the aesthetic senses, especially the sight.
- A combination of qualities that pleases the intellect or moral sense.

Adventure

- An unusual and exciting, typically hazardous, experience or activity.
- daring and exciting activity calling for enterprise and enthusiasm.

Entertainment

- The action of providing or being provided with amusement or enjoyment.
- An event, performance, or activity designed to entertain others.

Inclusion

- The action or state of including or of being included within a group or structure.
- The practice or policy of providing equal access to opportunities and resources for people who might otherwise be excluded or marginalized, such as those who have physical or mental disabilities and members of other minority groups.

Safety

- The condition of being protected from or unlikely to cause danger, risk, or injury.
- Denoting something designed to prevent injury or damage.

Flexibility

- The quality of bending easily without breaking.
- The ability to be easily modified

Pragmatism

- A pragmatic attitude or policy.
- An approach that assesses the truth or meaning of theories or beliefs in terms of the success of their practical application.

Stimulation

- Encouragement of something to make it develop or become more active.
- The action of arousing interest, enthusiasm, or excitement.
- The raising of levels of physiological or nervous activity in the body or any biological system.

Opportunities in Existing Objects

In this section, we will be ranking objects both in and out of Washington Park from which to draw inspiration for our project. We will be placing them into the categories of Education, Community, Relaxation, Necessity, Beauty, Adventure, and Entertainment. Within these categories, objects will be ranked on a radar-like chart consisting of 5 criteria: Inclusion, Safety, Flexibility, Pragmatism, and Stimulation.



More Successful Examples



Less Successful Examples

Education

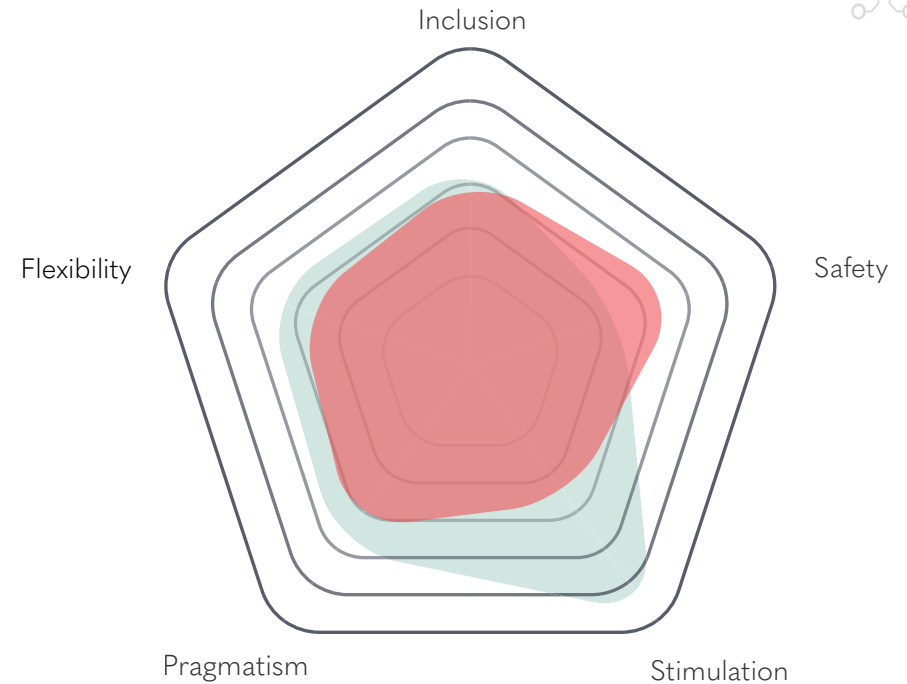

Education in public space refers to the fixtures such as memorials, plaques, and statues that reference the historical significance of an area. While stimulating, they can often be misunderstood or seem out of place to users who do not understand their meanings to the space.

Community

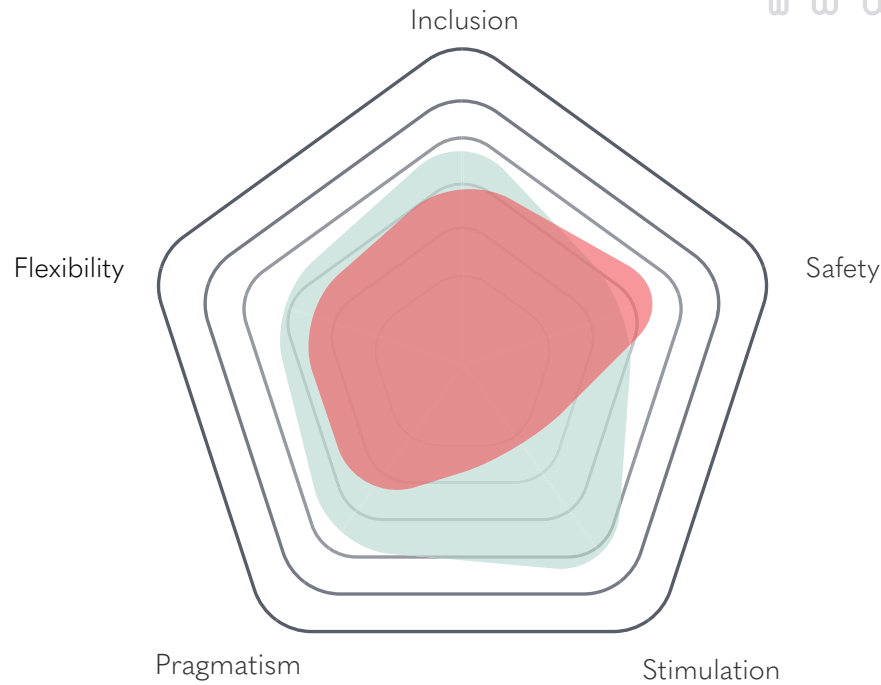

Community refers to a local population that maintains common ownership over an area. Park seating and dining areas help facilitate the gathering of community members but are often seen as inaccessible and sometimes even unsafe for users.

Relaxation

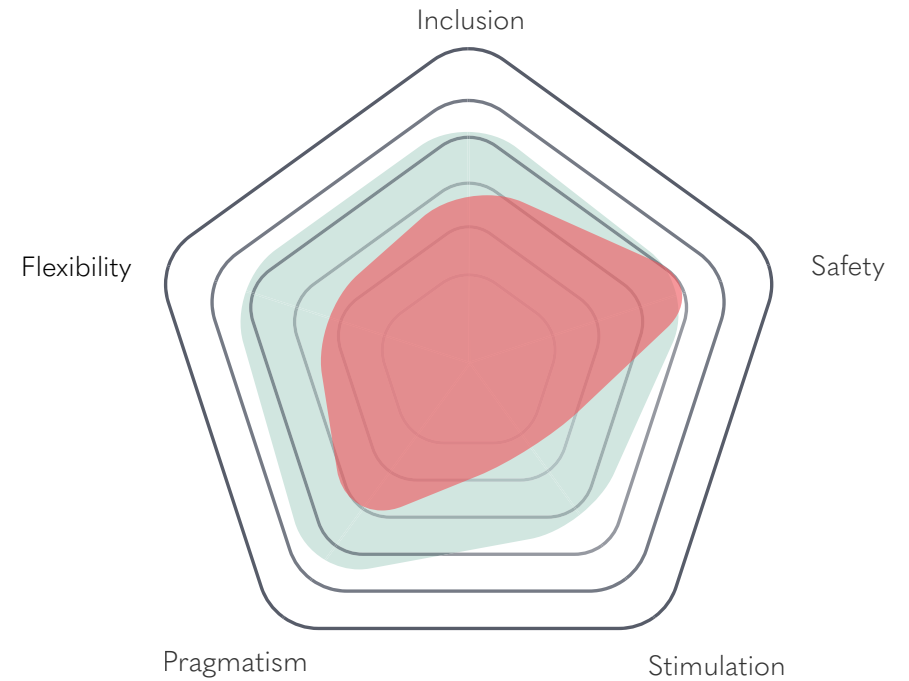

Relaxation attracts users to space as a means of escaping the stress and pressure of everyday life. Park fixtures encourage unwinding and de-stressing by increasing the comfort of users in the public space in a safe but unstimulating manner.

Necessity

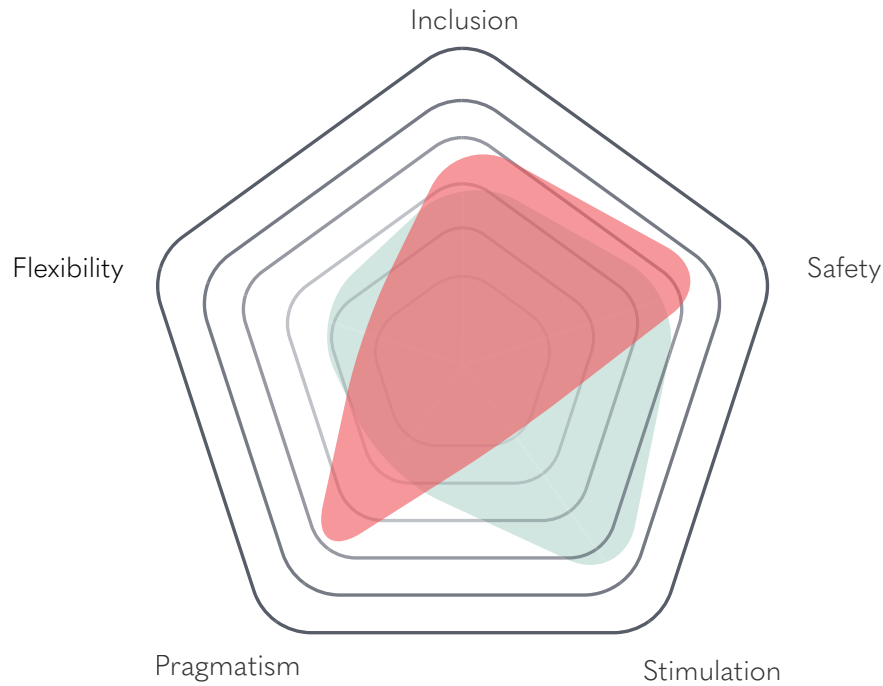

Necessity calls attention to fixtures that are vital to the maintenance and operation of public space. While the use of these fixtures is generally unstimulating, they are essential to keeping spaces inclusive and safe for all users.

Beauty

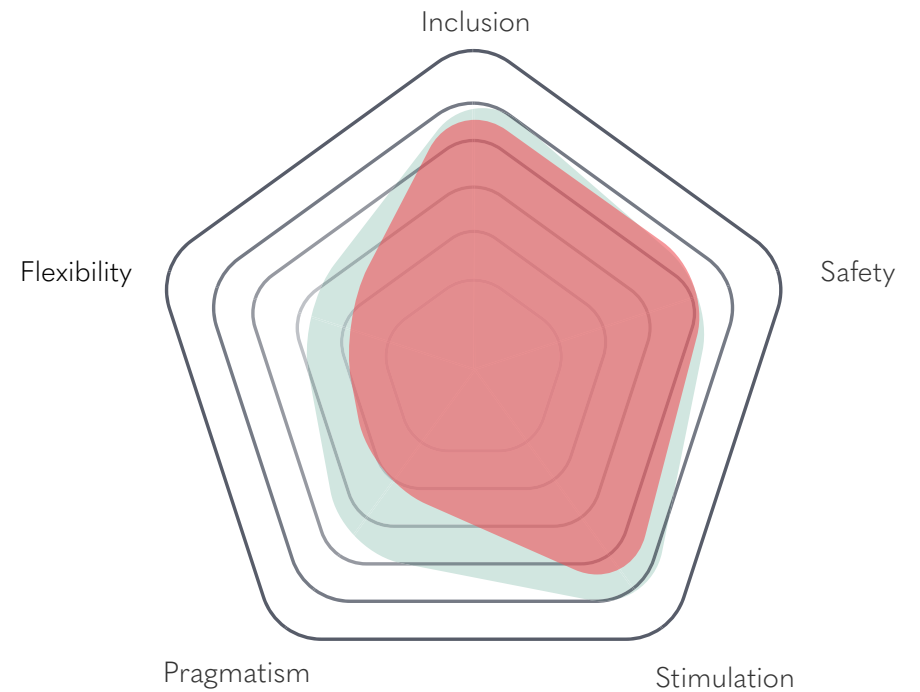

Beauty of public spaces is essential to stimulating and attracting users to a specific area or park. Art in public space may also be interpreted as controversial or a misuse of resources to users who do not understand its meaning.

Adventure

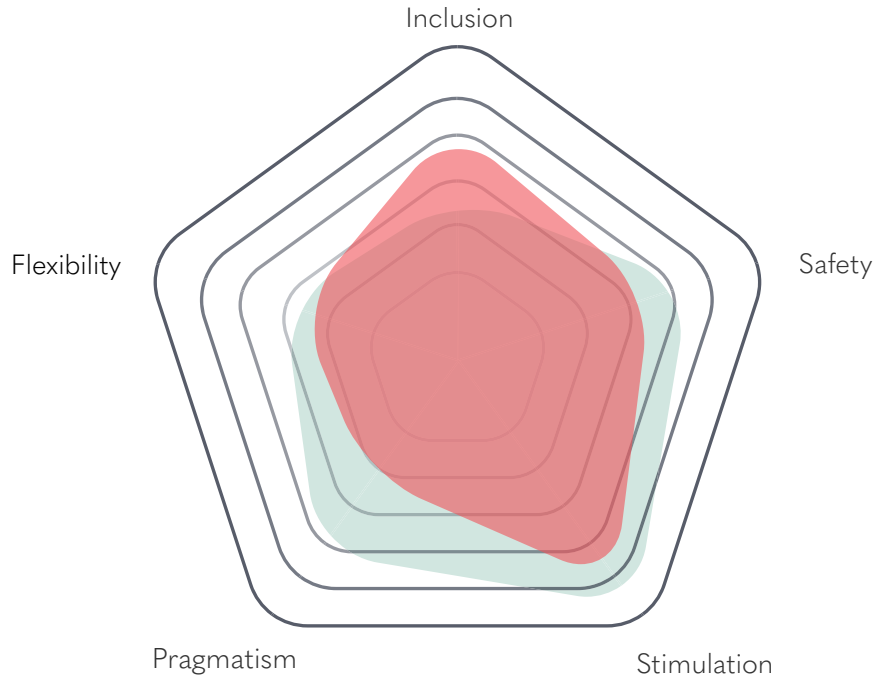

Purely adventurous public space can provide thrilling experiences to the public; however, they can be liable for risk, making them more expensive and harder to maintain.

Entertainment

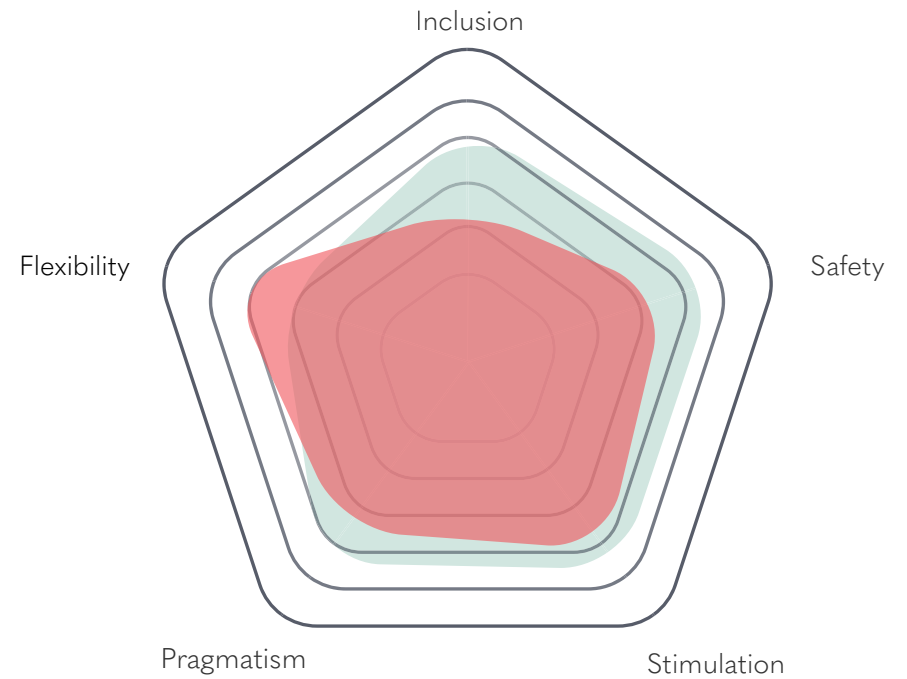

Entertainment is key in attracting and keeping users engaged in a public space. These types of fixtures are often stimulating but lack inclusivity and can be viewed as unsafe.

Ideation Process

After presenting our proposals to 3CDC, the first phase of design ideation began. For inspiration, the illustrations of *Okii Sato*, a Japanese designer, were analyzed for their quick and yet articulate nature. This allowed students to create loose concepts that focused more on function rather than aesthetics. Multiple rounds of design ideation saw loose concepts evolve into refined designs for the second phase of ideation. The next round of concept refinement saw the introduction of the production of fixtures. Topics of materials, dimensions, and manufacturing were addressed within teams assigned to specific proposals. Teams then chose and refined two designs further using more advanced tools such as CAD and physical modelmaking. For the final phase of design, each team chose one final concept for their proposal to fully refine and produce presentation materials for use in the final design meeting with 3CDC. Some of these materials included scale orthographics, rendered drawings, and supporting documents such as a bill of materials. The final seven concepts were then presented to 3CDC for valuable feedback to help better cater to the users' needs. From these seven concepts, four concepts were chosen to move forward with the production and installation into Washington Park.





Proposals
Chapter 05

Topography

The structure would provide a place for parents to sit/relax while their kids are playing in the water. The walls have a slight angle to capitalize on the usage of 3D printing. The two main forms can remain separate or be stacked on top of each other.

The vertical walls of the structure will be made of fiberglass using an industrial scale 3D printer. The lateral top of the form is composite decking drilled into a flange from the 3D printed wall. Internal support beams will be printed as needed to support the decking.

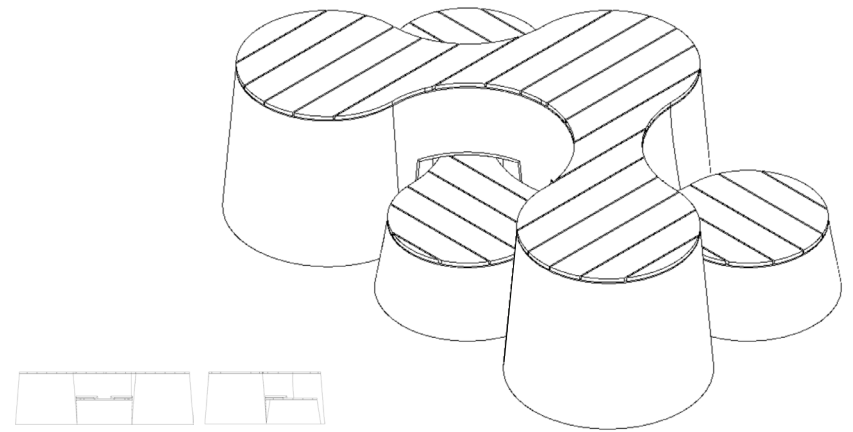

Material Composite Decking & 3D Printed Fiberglass

Dimensions H 30 in x W 70 in x L 104 in

Seesaw

A fun, modern take on the classic seesaw for Washington Park. Located near the childrens' park, this seesaw is large enough for kids and adults alike, and introduces a fun new challenge to the traditional playground activity. The furnishing can hold up to 8 people and is suitable for small or large families. The center of the seesaw mimics the handheld ball-in-maze game that is sometimes won as a prize at festivals. The players have to work together to tilt the seesaw in the right direction to guide the ball through the labyrinth to the center of the maze.

The project will be largely manufactured in-house, with the metal detailing being outsourced. The wood is red cedar and the seats will be made from a waterproof polyurethane foam upholstered in an outdoor vinyl.

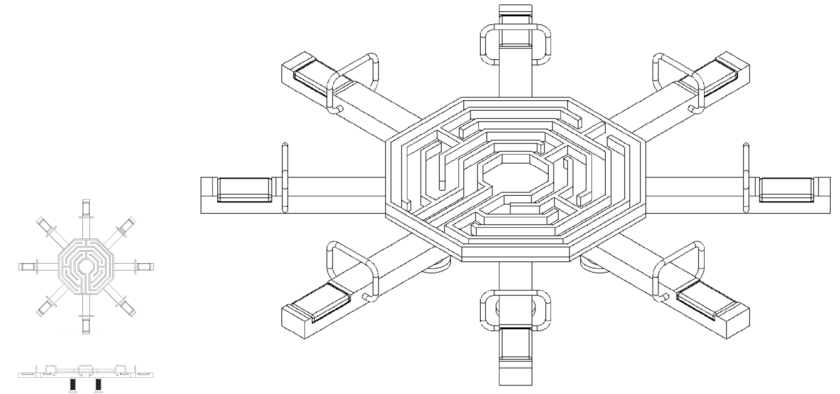

Material Red Cedar Wood, Metal, Foam Upholstered in Vinyl

Dimensions H 22 in x W 58 in x L 58 in

Earthworks

An earthworks-inspired lounge seating designed for groups in the south end of the park. Made from real dirt and grass to create an engineered hill for seating for park patrons.

The earthwork is made by structuring a waffle skeleton out of plywood and then filling that skeleton in with dirt and resources. We would take that a step further and place either composite decking or wood panelling that joints with the skeleton to create specific seating spots.

There are many opportunities to include nature such as landscaping and natural materials such as gravel or stone within the design.



Material Plywood, Dirt, Composite Decking/Wood Paneling
Dimensions H 42.5 in x W 18.5 ft x L 32.5 ft

Turf

Chosen for Fabrication

Interactive and versatile rocking arcs lined with realistic grass turf. These objects would function as singular units that can also be joined together to form an entire system. When standing alone, these forms can be primarily oriented in one of two ways; the first being a concave form that rocks. The second position would create a convex form that suggests the profile of a mound. When positioned on their side and joined together, these forms can produce semi-circular or winding partitions that users can reconfigure based on their needs (i.e. picnic nooks, dividers, extra shade, etc.)

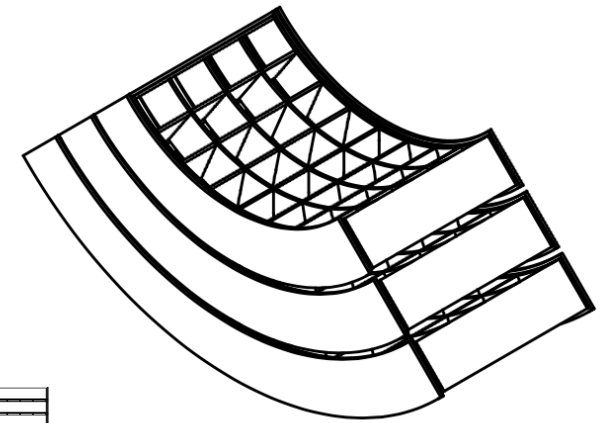

Material

Ply Wood, Expanded PVC, Turf, Polyurethane, Construction Adhesive and Nails

Dimensions

H 38.03 in x W 27.56 x L 83.06

Canopy

Chosen for Fabrication

Canopy is a shelter installation that focuses on a personal shaded area enhanced using the power of color and luminosity. Fabric shapes riveted together form an intricate colorful pattern that is cast down upon users resting under the arching fixture. Not only does canopy protect users from the sun but it also aims to create an intriguing environment for patrons to gather and relax within Washington Park

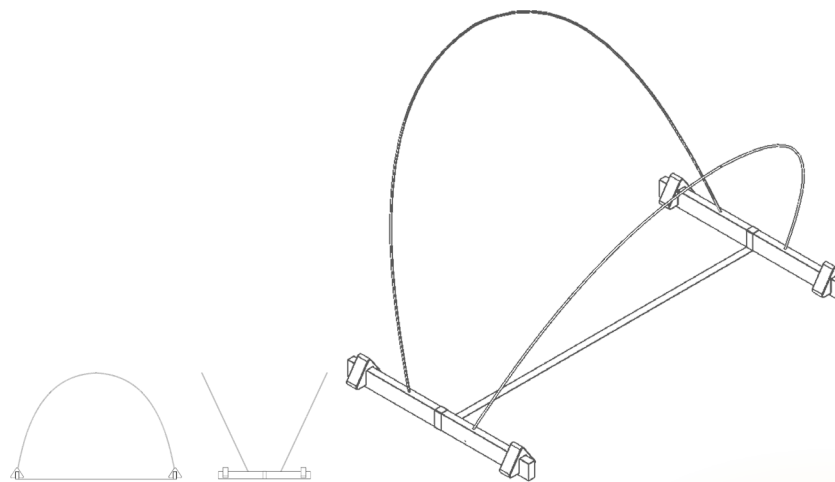

Material Steel, Molded Concrete, Fiberglass Poles, Nylon Ripstop, Grommets

Dimensions H 57.5 in x W 58 in x L 80 in

Flow

Chosen for Fabrication

Flow is a collection of furniture objects constructed using traditional linear building techniques, but creating non-traditional curvilinear forms. Imagery that's pertinent would be organic flowing shapes, wood and steel in curved forms, and sharp angles contrasted with flowing lines.

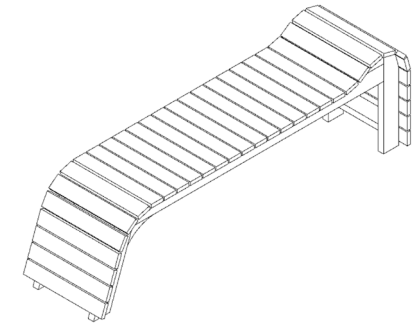

Material Cedar, Pine, Steel Screws, Latex Primer & Paint

Dimensions H 22 in x W 18 in x L 73 in

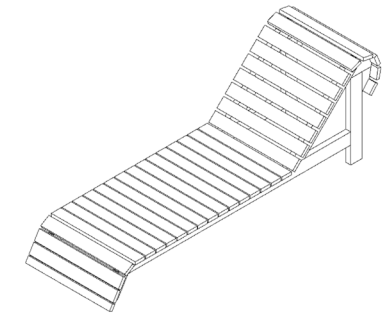
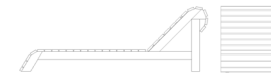

Material Cedar, Pine, Steel Screws, Latex Primer & Paint

Dimensions H 24.5 in x W 22 in x L 71.5 in

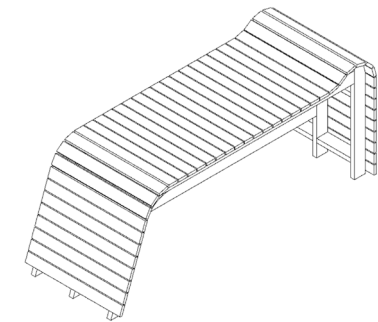

Material Cedar, Pine, Steel Screws, Latex Primer & Paint

Dimensions H 34 in x W 30 in x L 81 in

Modular

Chosen for Fabrication

Create a furnishing that allows the user to interact with it in multiple ways, allowing for inspiration and conversation. Having a piece of furniture that encourages customization creates a more versatile experience for all users.

With the diversity of users of Washington Park, the furniture invites interaction in multiple ways, allowing it to be multiorientational and movable. The objects can be flipped for different purposes- they can transform into tables to rest drinks on, lounges to relax on, and chairs to sit in and connect with friends at the park.

Fabricated using large industrial scale 3D printers with Cincinnati Incorporated. Specific materiality will be determined with the manufacturer, but they have a wide range of reinforcements that can be put inside the filament to make it stronger and more durable.

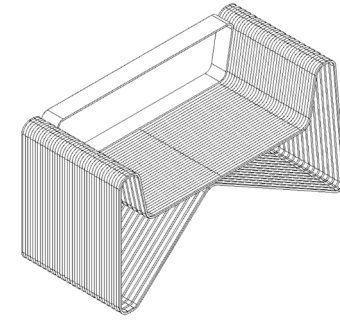

Material

Recycled Bottle Caps

Dimensions

H 30 in x W 25 in x L 57 in

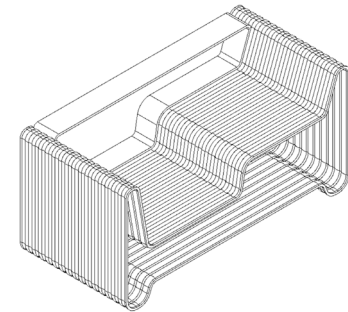

Material

Recycled Bottle Caps

Dimensions

H 20 in x W 20 in x L 42 in

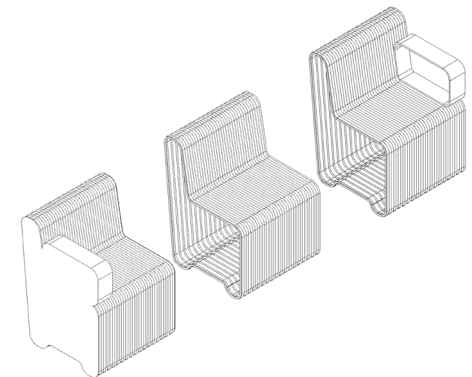

Material

Recycled Bottle Caps

Dimensions

H 30 in x W 22 in x L 22 in (Each)

Fabrication

From the original seven concepts, four designs were chosen to be fabricated and installed in Washington Park. Fabrication first began with the finalization of designs based on feedback given by 3CDC. Final plans for these designs were then drafted in CAD to aid in the planning and creation of the installations. Manufacturing first began with scale models to validate factors such as structural integrity and material exploration. With finalized and validated models, procurement of materials began for the full-sized fixtures. While lumber and hardware were purchased locally, some materials such as turf and 3D-printing required special orders and negotiation with vendors. After procuring the necessary materials, teams quickly began the manufacturing of their designs. The Turf and Flow teams utilized DAAP's build lab for woodworking and finishing of their fixtures. The Canopy team took advantage of services such as the University of Cincinnati's 1819 Innovation Center makerspace for laser cutting. Due to the Modular team's use of large-scale 3D printing, negotiations were made with a local manufacturer, Cincinnati Inc., to produce their models. Through hard work and dedication, the installations were manufactured and then installed in their respective places within Washington Park.











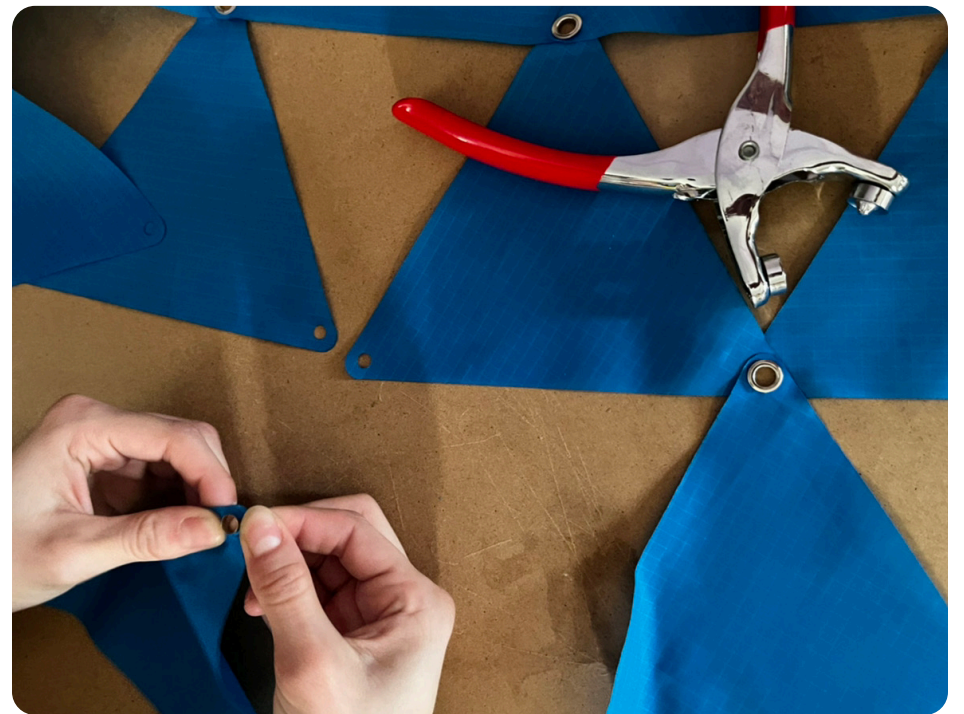
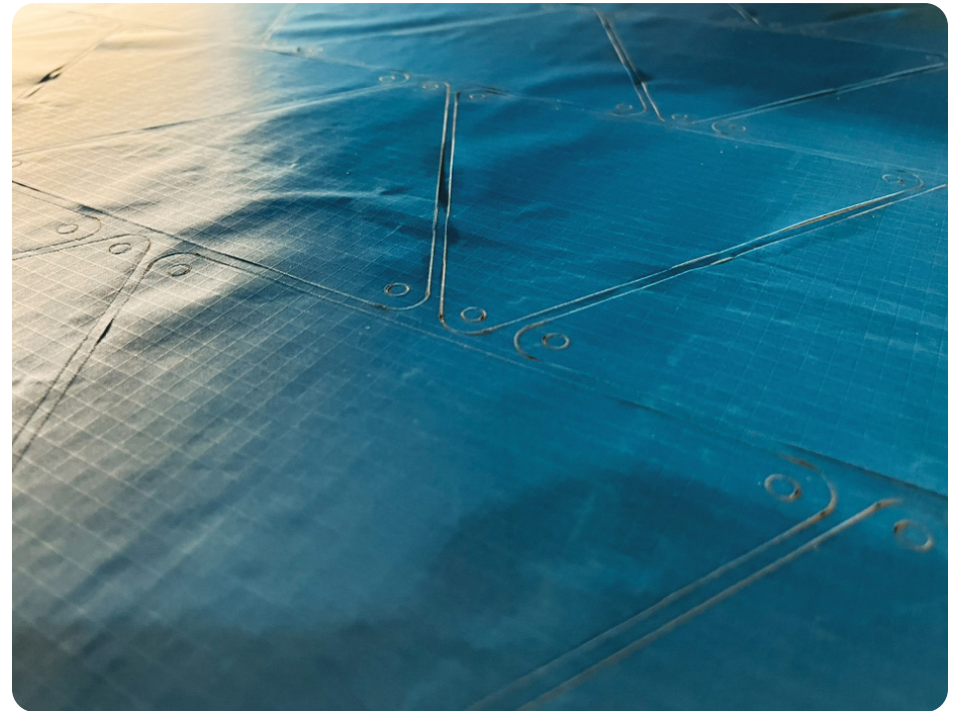
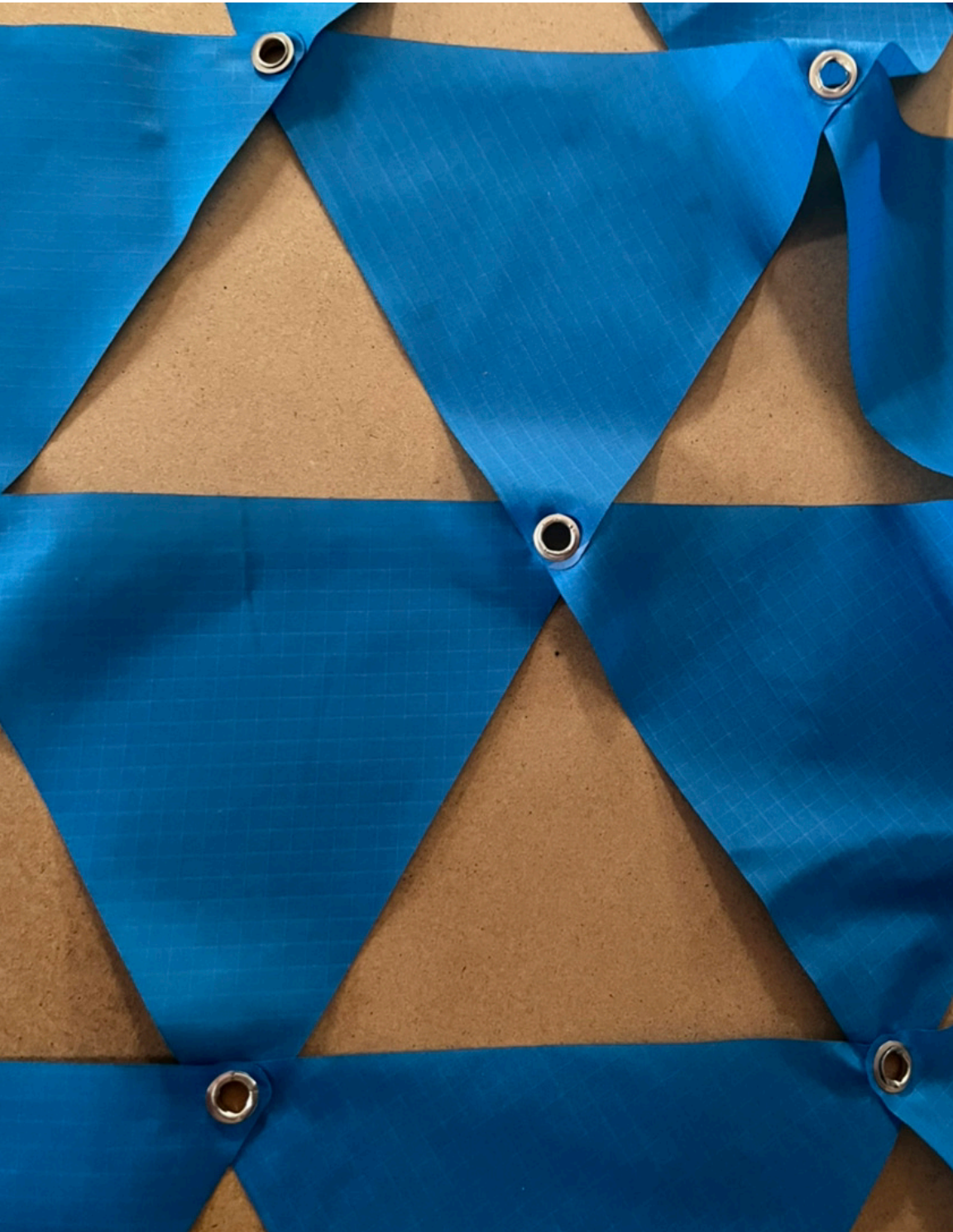









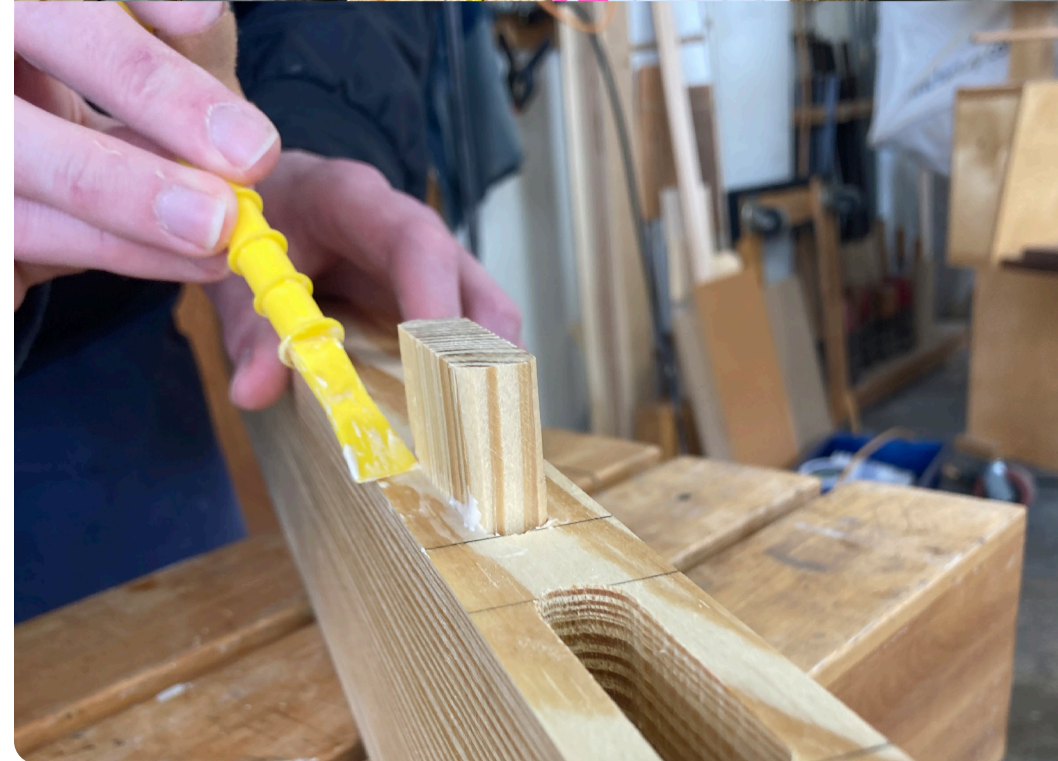



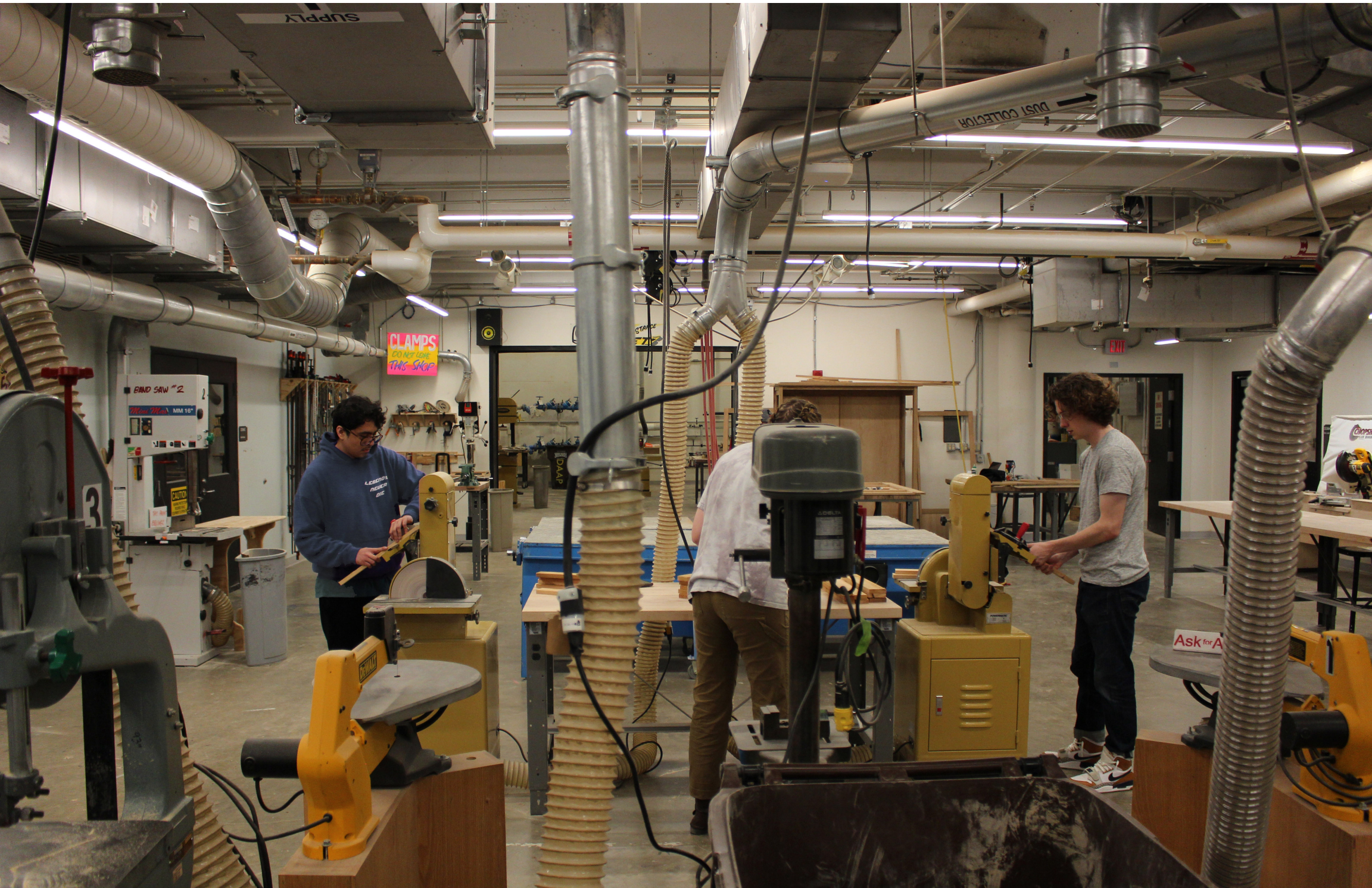





























at the
Park.
pets out
of areas
Help
an by
our pet.



















The Class
Chapter 06



John Dixon



Stephen Slaughter



Isa Herrada



Conrad Hiller



Dylan Maltry



Sarah Andrus



Riley Chang



Evan Cheevers



Logan Matson



Tian Pakko



John Pappalardo



Sarah Durbala



Emily English



Lea Glander



Ty Plassman



Katie Rieth



Peter Schmalz



Clair Grywalski

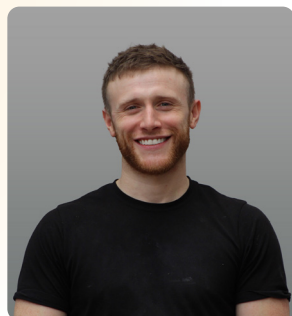

Alex Harrison



Virginia Hauberg



Spencer Tallman



Julian Torres

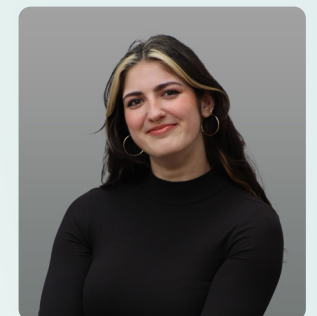

Nika Umnov

Special Thanks To

These organizations and the people within them: Cincinnati Incorporated, the 1819 Innovation Hub, the DAAP STL, the DAAP Build Lab, 3CDC, the City of Cincinnati, the folks at Washington Park, patrons of the park, and of course, the students and professors for making this project possible